

## WA-16.5 Passive Infrared Lens Array

### Short Focal Length, Uniform Sensitivity PIR Lens

The WA-16.5 is a Fresnel lens array that is designed for Passive Infrared (PIR) sensor applications. This lens can be used in applications involving security, lighting controls, and environmental controls. The lens is designed for uniform sensitivity, which means that each zone has approximately the same sensitivity as the others, and the total electronic gain of the sensor can be minimized. It features a 150 degree field of view and a short focal length that makes it well suited for compact, low profile sensors. This lens is best when used in short to medium range applications. It is ideal for units with swivel mount designs and can be used in conjunction with motion activated cameras. This lens array is an excellent candidate for lighting control applications.

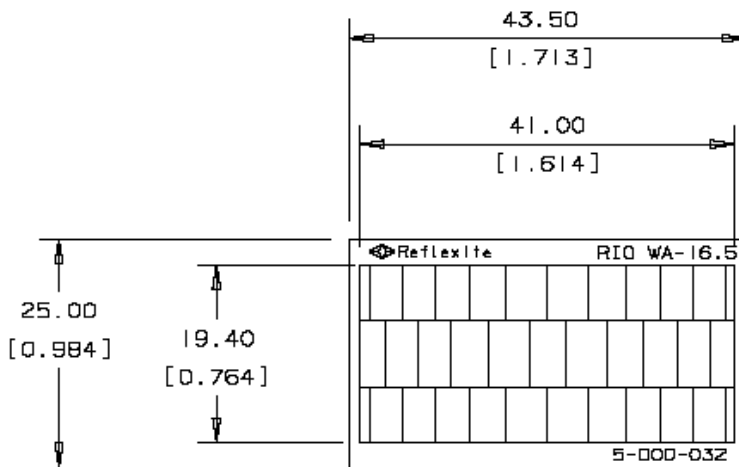

Lens Array Schematic

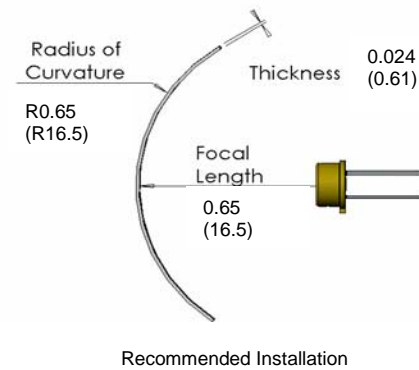

Recommended Installation

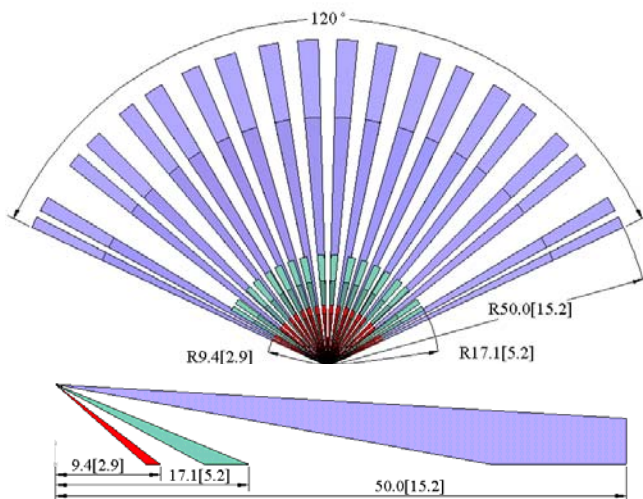

Sample Protection Pattern

### Specifications:

- Reflexite Part #IO8904
- Range: 50 ft (15.2m).
- Field of View: 120°
- Installation Height: 7-10 ft. (2.1– 3 m).
- Focal Length: 16.5 mm
- Material: HDPE
- Colors: White, Grey, and Natural.
- Optimized for dual element pyroelectric devices.
- Uniform sensitivity for improved sensor efficiency.
- White light immunity to reduce false triggers.
- UV resistant for outdoor applications.
- Dimensions are in inches (mm)

Reflexite® is a registered trademark of Reflexite Corporation, Avon, CT, USA  
 Technical Publication RIO-180, Pub. 2003, Rev. 3  
 © 2006, Reflexite Display Optics